

### SEAT HEIGHT ADJUSTMENT

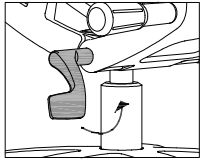

To raise the chair, lift the lever up while lifting your weight from the seat until you reach the desired level, then release to lock in place. To lower the chair, lift the lever up and allow your weight to push the seat down until you reach the desired level, then release to lock in place.

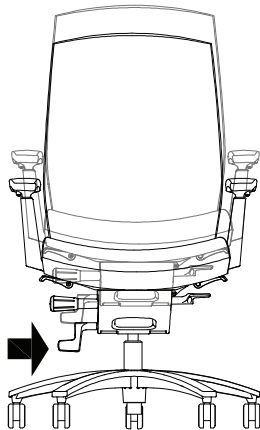

### BACK TILT ADJUSTMENT

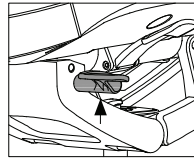

To adjust the angle of reclination, push the lever down to unlock the back. Recline to the desired position and lift the lever up to lock in place or leave to allow backrest to recline freely.

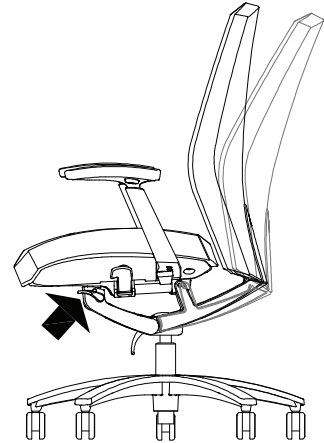

### SEAT DEPTH ADJUSTMENT

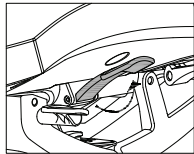

To adjust the seat depth, lift the lever up and simultaneously lift your weight from the seat while sliding the seat forward or backward. Release lever to lock the seat in place.

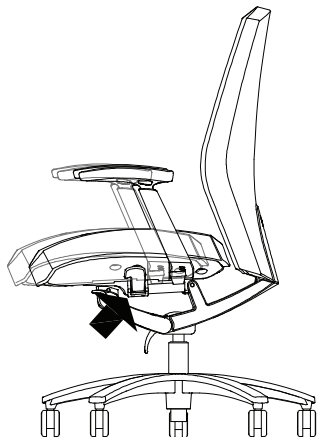

### TILT TENSION ADJUSTMENT

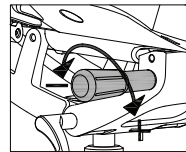

Leaning back, determine if the resistance of the chair is comfortable. For less resistance, pull tension adjustment knob out and turn it counter clockwise. For greater resistance, turn the knob clockwise.

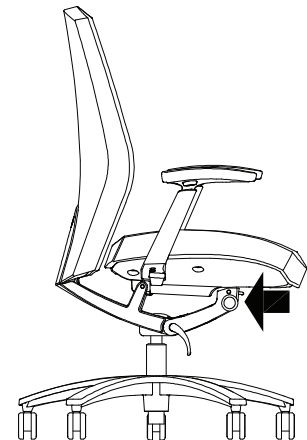

### ARM HEIGHT ADJUSTMENT

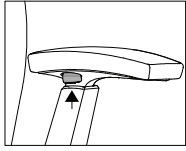

To adjust the arm height, press the button located under the armrest to raise or lower it to the desired position. Release the button to lock in place.

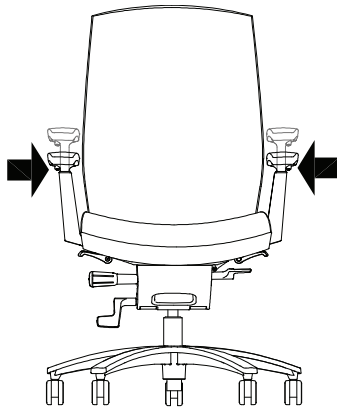

### ARM WIDTH ADJUSTMENT

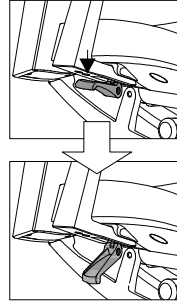

To adjust width of each arm, push the lever down and slide the arm to the desired position. Push the lever up to lock the arm in place.

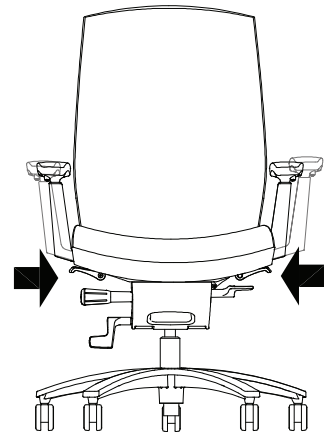

### ⚠ Warning

Tipping or collapsing can result in serious injury. To prevent product failure and possible injury:

- This chair has been designed and tested for users weighing up to 300 lbs
- Frequently inspect the chair for visible cracks and damages, tighten all screws, bolts, adjustable knobs and parts
- Do not use the chair if damaged or unstable – immediately remove it from service
- This chair is equipped with casters intended for use on carpeted surfaces. Use of these casters on hard surfaces could result in unexpected rolling and tipping. Casters designed for use on hard surfaces are available. If in doubt, see your dealer for appropriate selection
- Do not stand on or use the chair as a step ladder
- Failure to follow these warnings could result in serious injury