



Teknion systems

t|o|s



T/O/S® is a proven, performance-based panel system that set the benchmark for flexibility and efficiency in office furniture planning. Designed to keep pace with evolving workplace needs, T/O/S remains as versatile and valuable as ever — offering functional and aesthetic compatibility with past and future T/O/S products.

T/O/S provides significantly lower cost of change within the office environment, allowing users to realize reduced ownership costs over the life of the product. Highly competitive at purchase, T/O/S provides an excellent return on investment.

T/O/S supports long-range facilities plans by providing these key attributes:

- Modularity – Modular components that support on- and off-module planning make it possible to plan a workspace that fits individual and organizational needs.
- Reconfigurability – T/O/S can be installed and reconfigured quickly and easily.
- Strength and Durability – T/O/S is designed and engineered to ensure product integrity and longevity.
- Product Integration – T/O/S works with other Teknion product lines to expand planning possibilities.
- Data/Power Management – T/O/S offers high cable capacity and convenient work-surface access.

traditional/semi-enclosed

modern/open

team/collaboration

enclosure/privacy



# Traditional/ semi-enclosed

T/O/S opens up the traditional 66-inch high workstation by providing the option to vary and step down the height of wing panels, as well as offering Glass Elements that may be added for greater light transmission. The option to replace worksurface end-of-run panels with legs also affords an opportunity to create a sense of lightness and openness.

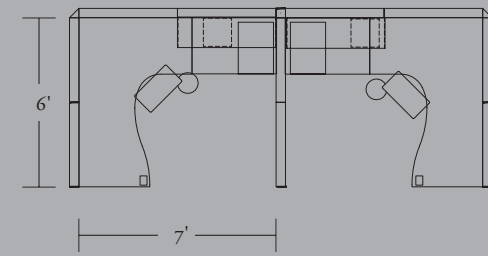

PANELS:  
*Fabric – Nitty Gritty,  
Mood  
Elements – Architectural  
Glazed  
Frames – Mica, Platinum*

WORKSURFACES:  
*Foundation Laminate,  
Storm White*

STORAGE:  
*Mica, Platinum*

SEATING:  
*Contessa,  
Frame – Tess Silver  
Upholstery – Tess Mesh,  
Light Blue*

# Modern/open

T/O/S achieves a lighter, more open look with space division options such as translucent Add-On Screens and upmount storage that allows the workstation to be built-up to accommodate more storage in a small space.

To support its sustainability goals, Teknion offers renewable, biodegradable panel fabrics as a sustainable textile option. Spiral (*shown*) and Speckles are made from a biodegradable polylactide (PLA) polymer resin that is derived from corn, a 100 percent renewable resource.

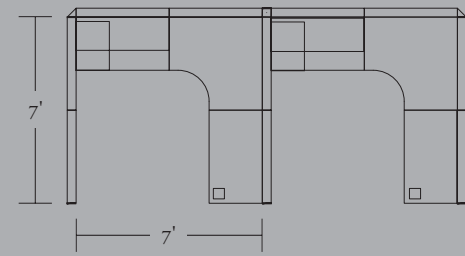

PANELS:  
*Fabric – Spiral, Doodle  
Frames – Mica, Platinum*

ADD-ON SCREENS:  
*Translucent*

WORKSURFACES:  
*Foundation Laminate,  
Storm White*

STORAGE:  
*Mica, Platinum case  
with Translucent doors*

SEATING:  
*Contessa,  
Frame – Tess Silver  
Upholstery – Tess Mesh,  
Light Grey*

Team/collaboration

The office environment is often comprised of interdisciplinary, multi-tasking teams. T/O/S responds to team applications with varied surface shapes such as transaction tops, corner split worksurfaces, and guest worksurfaces that facilitate collaboration.

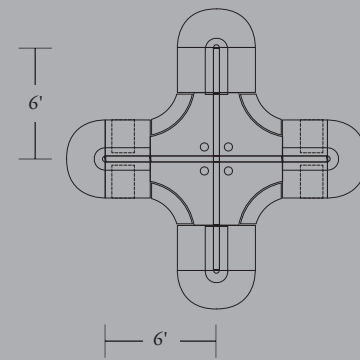

- PANELS:  
*Fabric – Speckle, Appaloosa*  
*Frames – Mica, Bronze*
- WORKSURFACES:  
*Foundation Laminate, Smokey Walnut*
- STORAGE:  
*Mica, Bronze*
- SEATING:  
*t-3, Back – Mesh*  
*Seat – Leather, Black*

^ Curvilinear tops create a shared meeting space at the end of a workstation. Countertops create transaction surfaces ideal for collaborative work areas.

v Power and data are delivered to the user at desk height via the Access Door or Face-mounted Power/Communications Element. Ease of access simplifies change.

Enclosure/privacy

T/O/S can be built up to ceiling height when a high level of enclosure and privacy is required. Double-sided Glass Elements preserve a sense of openness and admit light, yet maintain privacy. When integrated with Almanac Overhead Cabinets and the Combination Cabinet, T/O/S provides a high-end look for executive settings.

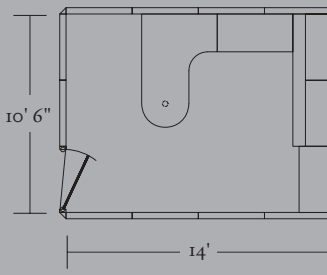

PANELS:  
*Fabric – Linen Weave, Slope*  
*Frames – Mica, Platinum*

WORKSURFACES:  
*Flintwood, Dark Olive*

STORAGE:  
*Cases – Mica, Platinum*  
*Fronts – Flintwood, Dark Olive*

SEATING:  
*Harrington, Amicus Guest - Leather, Shale*

^ Elements and trims are also available in a square profile to offer a different aesthetic option.

Thirty-two-inch-high Elements are ideal for exterior panel application where an access door may not be required.

PANELS:  
*Fabric – Speckle, Fleck*  
*Frames – Mica, Platinum*

# Modularity

The advantage of T/O/S lies in the inherent versatility of its panel design. T/O/S panels not only divide space, they also provide modularity in height, component attachment and space planning.

### STACKABLE PANELS

- Panel height may be increased by adding 15-inch Add-On Modules that are easily installed on-site
- Maximum height flexibility is achieved with the Super Panel. It is shipped assembled to the preferred height, but constructed of 15-inch modules that are easily added or removed on-site
  - allows panel height to be built up or down on-site without disrupting the workstation
  - minimizes inventory as one panel style can be used for spine or wing planning in all applications

### ELEMENTS PROGRAM

- To modify the look or function of a workspace, all panel Elements can be interchanged or replaced on-site
- Common heights permit variations in Element location, including different styles on either side of a panel

### ON-/OFF-MODULARITY

- Panels, worksurfaces and mounted storage may be attached at any point laterally along a panel run, regardless of panel width
- This on- and off-modular feature is permitted by the unique design of mounting brackets and structural supports built into the panel frame

### BENEFITS

- Planning versatility and simplicity
- The initial investment is protected by the product's ability to easily add, remove or relocate components, allowing reversible decision-making
- Change the function or look of a workspace with minimal new inventory, without having to remove the panels
- Ability to stack while power/data is installed
- Changes can be made immediately, saving time and costs

# Reconfiguration

T/O/S is designed to support change and quickly reconfigure workspaces, using virtually the same components. T/O/S includes a number of features that help control the cost of change.

### PANEL HEIGHT

- To accommodate overhead storage or vary the degree of enclosure, simply add or remove 15-inch modules

### NON-HANDED SUPPORTS

- Reconfiguration is facilitated with non-handed supports that can be used with worksurfaces of any depth
- Planning is simplified with unique panel rails designed to support worksurfaces at the side, making it unnecessary to consider the depth of adjacent panels

### ELECTRICS

- Access to power and communications is at desk-height via the Access Door, always positioning electrics at the same height throughout planning and reconfiguration
- Electrical harnesses may be added without removing worksurfaces or support hardware, with no disruption to the workstation

### BENEFITS

- Reduces overall cost of ownership
- Maximizes use of inventory, as existing components are reusable
- Minimizes reconfiguration downtime and loss of productivity
- Panel height can be changed with no disruption to the footprint
- Minimal labor costs for reconfiguration

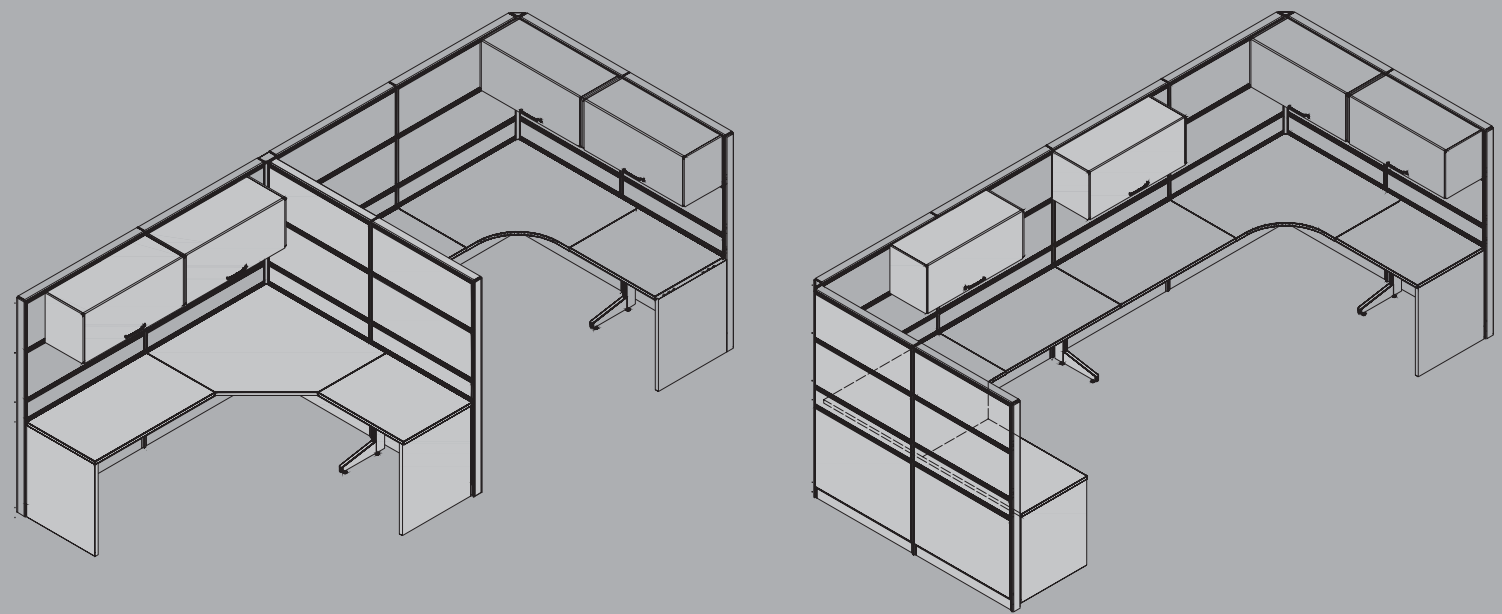
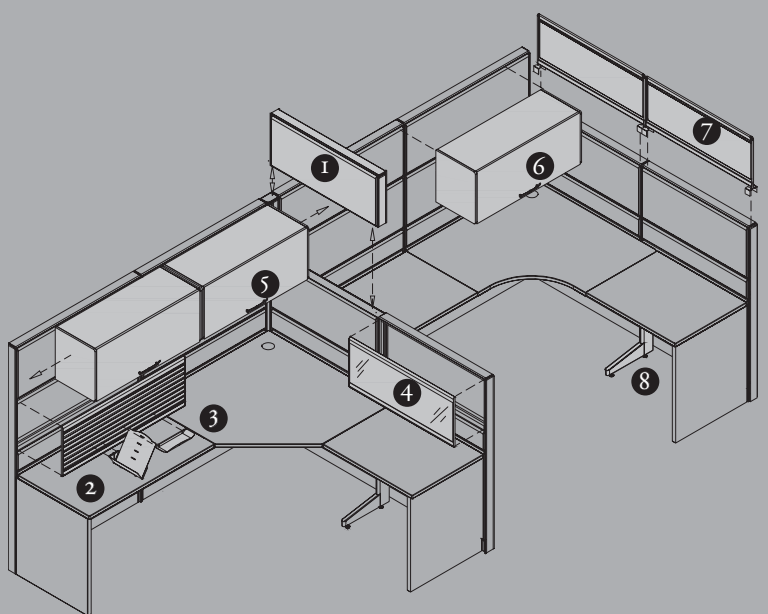

Before

After

- 1 Panel Add-On Modules can be quickly stacked or removed to accommodate change.
- 2 Accessory Elements can be easily added to increase workstation functionality.
- 3 Personal Organizers allow the user to quickly personalize their workstation.
- 4 Glass Elements, in Clear or Frost Glass, provide different levels of visibility and light transmission.
- 5 Overhead storage cabinets move laterally anywhere along a panel in on- or off-module applications to suit user needs.
- 6 Overhead cabinets can be easily added to panels when additional storage space is required.
- 7 Panel Add-On Screens provide space division, easily mounting onto panels.
- 8 Supports are non-handed and work on- or off-module for maximum versatility.

T/O/S individual workstations can be reconfigured using virtually the same components within the same footprint.

This T/O/S teamwork environment has been restructured from existing components to reflect changes in workstyles or staff.

# Strength and durability

T/O/S is designed and engineered to ensure product integrity and optimal strength over the long term, thereby sustaining the continued restructuring of the workplace. T/O/S is built to last.

- The structural integrity of the steel frame enables maximum load-bearing capability from 36 inches to ceiling height
- Panels attach with metal-to-metal connectors, ensuring strong connections and stability
- Electrostatic application of powder paint on all surfaces ensures safe cable routing
- Metal inserts allow worksurfaces to be reconfigured without damage

**BENEFITS**

- Exceptional performance
- Planning versatility
- Simple, quick installation with solid weight-bearing connections
- Product longevity reduces long-term cost of ownership

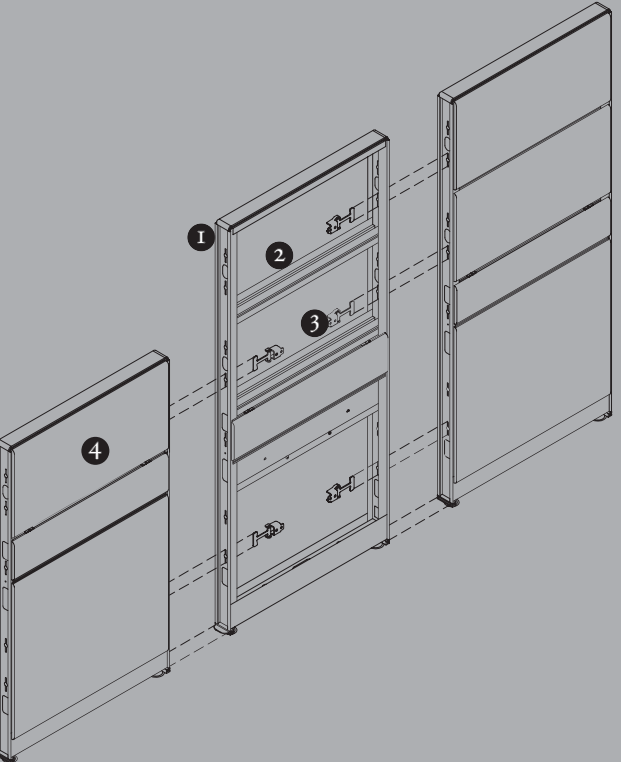

- 1** A unitized, welded frame of all-steel construction supports weight-bearing applications and ensures rigid assembly.
- 2** Segmented frames with horizontal members allow off-module applications.
- 3** Metal-to-metal connections provide simple installation with solid weight-bearing connection.
- 4** A 3 3/4-inch panel thickness allows high-capacity cable management.

# Product integration

T/O/S components combine with other Teknion products to add planning options and to balance desired features with budgets.

**LYFT**

- When the need is simply to divide space, Lyft™ space division products provide an alternative to wing panels and Add-On Modules
- Lyft becomes an extension of T/O/S across a full range of applications, from private office to collaborative work spaces

**FILING & STORAGE**

- Teknion's Filing & Storage products offer distinctive looks and multiple applications, including freestanding and panel-mounted
- Overhead cabinets panel-mount on- or off-module and can be applied with an upmount for use with lower-height panels

**BENEFITS**

- Expands planning versatility
- Existing products can be used for new applications
- New and existing products integrate to update a floorplate without the expense of replacing products that are not obsolete
- Extends the life of existing T/O/S furniture

**COMPLEMENTS**

- The Complements program includes ergonomics products that promote healthy working postures and accessories that organize and personalize a workspace

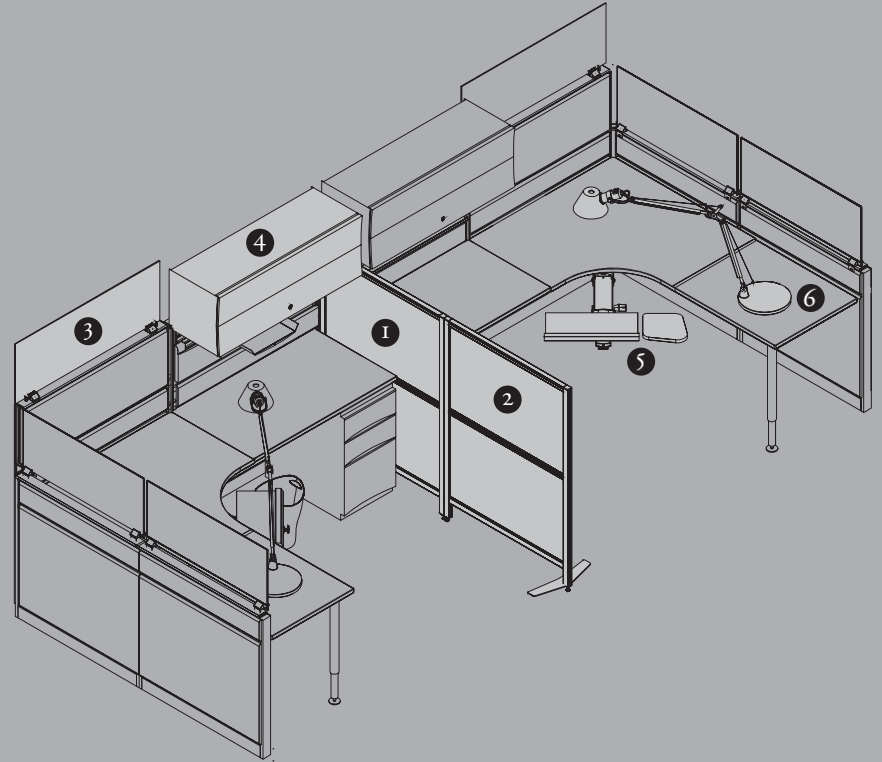

- 1** Lyft Thin Panels connect to T/O/S panels on- and off-module, or to other Lyft Thin Panels. The panel mid-rail accommodates worksurface connection and support, both on- and off-module.
- 2** Lyft Thin Panels are offered in three styles: Standard, Segmented and Monolithic. The top and bottom segment can be specified in different finishes – Fabric, Translucent and Whiteboard.
- 3** Lyft Add-On Screens provide visual privacy as an aesthetic and cost-effective alternative to load-bearing Add-On Modules.
- 4** The Universal Overhead is designed with a two-piece front to accommodate varied looks: Metal, Perforated Metal, Laminate, Veneer, Translucent, Erasable Whiteboard.
- 5** Complements Keyboard Arms feature 360° arm rotation and intuitive height and tilt adjustments. Keyboard Arms work in conjunction with any Keyboard Platform to provide effective ergonomics.
- 6** The Complements program offers adjustable task lighting that allows users to control the position of the light and intensity of illumination required.



# Data/power management

The T/O/S panel capably distributes power and data to the workstation and delivers it to the user. High-capacity power poles, lay-in modules and multiple circuit systems support varying power requirements.

- All T/O/S panels are equipped with raceways, a built-in power management duct that combines access to power and cabling at desk-top height with minimum visibility
- Raceways allow separation of power cables from data lines
- For future expansion, the raceway supports a modular, multiple-circuit harness system for additional circuits using a quick connector
- High-capacity data management is supported via a cable lay-in method or passed internally from panel to panel with integral cable management clips

## BENEFITS

- Electrical and communications cables can be changed or added without dismantling workstations, minimizing downtime
- To reduce potential interference, high-voltage wiring is shielded from communications cabling
- Planning and installation are simplified with a one-size harness and color-coded male/female connectors
- Cabling solutions yield savings on both initial and reconfiguration costs

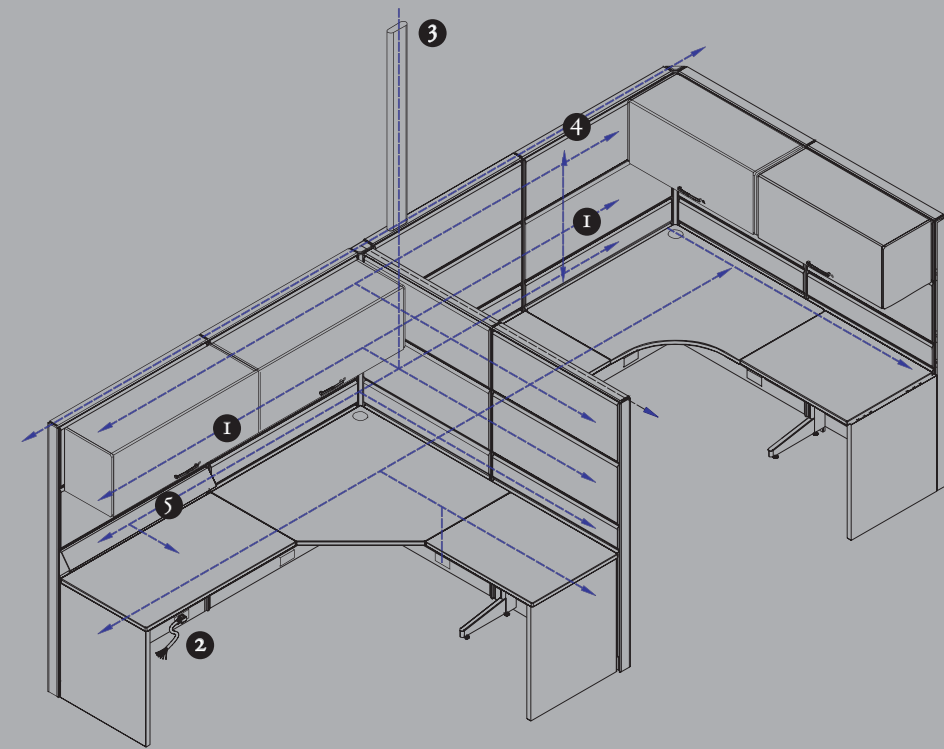

## ^ Data

- 1** Data wires can be run vertically and horizontally at every level, providing maximum cable carrying capacity.
- 2** Base feed access supplies a floor-level entry point through knockouts in every panel, providing ease of access to data in raised floors.
- 3** Power Pole routes data cables from building ceiling into panel. Split Power Pole simultaneously accommodates data cabling.
- 4** A cable Lay-In Module can be applied to the top of panels. The trough provides increased integrated communications cable carrying capacity of 60 Category 5 cables.
- 5** Hinged Access Door provides easy desk-height access to Voice Data Modules and other data and communications wires inside the panel.

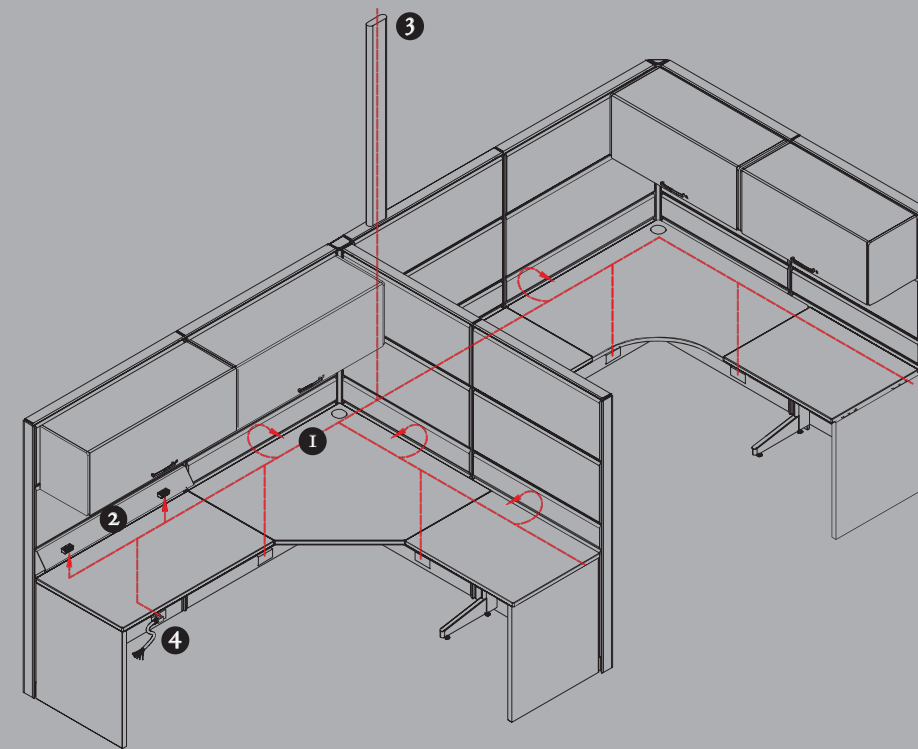

## ^ Power

- 1** Panels provide a safe conduit for power cables within a secure raceway.
- 2** Hinged Access Door provides easy work-surface-height access to power outlets.
- 3** Power Pole routes data cables from building ceiling into panel. Split Power Pole simultaneously accommodates power cabling.
- 4** Base feed opening supplies a floor-level entry point through knockouts in every panel.

# At a glance

<p>Panels</p>	<p>h 36", 42", 51", 60", 72", 81" w 18"-60"</p> 	<p>h 36", 51", 66", 81" w 18"-60"</p> 	<p>h 36", 51", 66", 81" w 18"-60"</p> 	<p>h 6", 15" w 18"-60"</p> 	<p>h 15" w 18"-60"</p> 	<p>h 9"-18" / 19"-30" w 18"-60"</p> 	<p>h 30", 45" / (end) 51", 66" w 18"-60"</p> 	<p>h 36", 42", 51", 66" w 18"-60"</p> 	<p>h 81" w 36", 42"</p> 	<p>h 51", 66", 81" w 36", 42"</p> 			
<p>Lyft</p>	<p>h 42", 51", 66" w 24"-60"</p> 	<p>h 51", 66" w 42", 48", 60"</p> 	<p>h 42", 51", 66" w 24"-48"</p> 	<p>h 42", 51", 66" w 24"-60"</p> 	<p>h 13", 22" w 24"-60"</p> 	<p>h 15" w 18"-60"</p> 	<p>h 15" w 18"-60"</p> 						
<p>Elements</p>	<p>acoustic h 6", 15", 24", 26", 30", 32", 36", 45" w 18"-60"</p> 	<p>tackable h 6", 15", 24", 30", 36", 45" w 18"-60"</p> 	<p>access door/ split access door h 6" w 18"-60"</p> 	<p>face-mounted power/ communications element h 6" w 18"-60"</p> 	<p>glazed - single + double h 15" w 18"-60"</p> 	<p>open h 15" w 18"-60"</p> 	<p>accessory h 6", 15" w 18"-60"</p> 	<p>grill h 15", 26" w 18"-60"</p> 	<p>whiteboard h 15", 30" w 18"-60"</p> 	<p>flintwood h 6", 15", 30" w 18"-60"</p> 	<p>architectural glazed - single + double h 15" w 18"-60"</p> 	<p>architectural h 15", 26" w 18"-60"</p> 	<p>architectural access door h 6" w 18"-60"</p> 
<p>Worksurfaces and Countertops</p>	<p>d 20", 24", 30" w 24"-96"</p> 	<p>d 36", 42", 48" w 19", 24", 30"</p> 	<p>d 42", 48" w 24", 30"</p> 	<p>d 42", 48" w 24", 30"</p> 	<p>d 30"-60" w 19", 24", 30"</p> 	<p>d 30", 36" w 24", 30"</p> 	<p>d 24", 30" w 36"-48" / 48"-84"</p> 	<p>d 24", 30" / 19", 24" w 24"-48"</p> 	<p>d 24", 30" w 24"-48"</p> 	<p>d 24", 30", 36" w 48"-72"</p> 	<p>d 24", 30" w 60"-84"</p> 	<p>d 24", 30" w 60"-84"</p> 	<p>d 24", 30" w 24", 30"</p> 
<p>Freestanding Desks</p>	<p>d 24", 30", 36" w 24"-72"</p> 	<p>d 24", 30", 36" w 24"-72"</p> 	<p>d 24", 30", 36" w 24"-72"</p> 	<p>d 24", 30", 36" w 24"-72"</p> 	<p>d 24", 30", 36" w 24"-72"</p> 	<p>d 36", 42", 48" w 19", 24", 30"</p> 	<p>d 30"-48" w 24", 30"</p> 	<p>d 42", 48" w 24", 30"</p> 	<p>d 24", 30" / 19", 24" w 24"-72"</p> 	<p>d 24", 30" / 19", 24" w 24"-72"</p> 	<p>d 24", 30" / 19", 24" w 24"-72"</p> 	<p>d 24", 30", 36" w 48"-72"</p> 	<p>d 24", 30", 36" w 48"-72"</p> 
<p>Tables</p>	<p>dia 30", 36", 42"</p> 	<p>w 30", 36", 42"</p> 											
<p>Mounted Storage</p>	<p>h 13", 16" w 30"-60"</p> 	<p>h 13", 16" w 30"-60"</p> 	<p>h 13" w 30"-60"</p> 	<p>h 13" w 24"-60"</p> 	<p>h 10" w 24"-60"</p> 								
<p>Freestanding Storage</p>	<p>d 18", 22", 28" h 21", 24", 27" w 15"</p> 	<p>d 18" h 27" w 30"</p> 	<p>d 18" h 27" w 30", 36", 42"</p> 	<p>d 18" h 16", 27", 41", 50", 54", 65" w 30", 36", 42"</p> 	<p>d 18" h 16", 27", 41", 50", 54", 65" w 30", 36", 42"</p> 	<p>d 18" h 65" w 30", 36", 42"</p> 	<p>d 24" h 65" w 24", 30", 36"</p> 						
<p>Handle options</p>	<p>standard pull</p> 	<p>full pull</p> 	<p>recessed pull</p> 										

TEKNION CORPORATION

IN CANADA:

1150 FLINT ROAD  
TORONTO, ONTARIO  
M3J 2J5 CANADA  
TEL 416.661.3370  
FAX 416.661.4586

IN THE USA:

350 FELLOWSHIP ROAD  
MT LAUREL, NEW JERSEY  
08054 USA  
TEL 877.TEKNION  
877.835.6466  
FAX 856.552.5088

OTHER OFFICES LOCATED IN:

EUROPE  
SOUTH AND CENTRAL AMERICA  
MIDDLE EAST  
ASIA  
RUSSIA  
FOR REGIONAL CONTACT  
INFORMATION GO TO  
[www.teknion.com](http://www.teknion.com)

TEKNION EMBRACES CHANGE AND ITS INNATE POSSIBILITIES. OUR CULTURE IS ONE OF INNOVATION. IN THAT SPIRIT, WE HAVE STEPPED FORWARD TO INTEGRATE SUSTAINABLE PRINCIPLES AND PRACTICES INTO THE DESIGN, MANUFACTURING AND MARKETING OF OUR PRODUCTS.

TEKNION PRODUCTS PERFORM INDEPENDENTLY AND IN CONCERT, COMBINING IN VIRTUALLY UNLIMITED CONFIGURATIONS. OUR PHILOSOPHY EMBRACES DESIGN AS ONE OF THE BEST TOOLS WE HAVE FOR REALIZING THE BENEFITS OF BUSINESS, WHILE ALSO STRIVING TO REACH SUSTAINABLE GOALS.

WE HAVE LEARNED FROM DESIGN THAT CHANGING A SINGLE DETAIL ALTERS THE WHOLE. EVERY INCH MAKES A DIFFERENCE. EVERY LEAP IS THE SUM OF MANY SMALL STEPS.

TEKNION CREATES FURNITURE THAT CONNECTS PEOPLE, TECHNOLOGY AND SPACES; INTEGRATED DESIGN WITH NEW POSSIBILITIES FOR A HEALTHY, PRODUCTIVE WORLD TOMORROW AND THE DAY AFTER.

CAN/US/INT 05-10

©TEKNION 2005-2010

®, ™ TRADE MARKS OF TEKNION CORPORATION AND/OR ITS SUBSIDIARIES OR LICENSED TO IT. PATENTS MAY BE PENDING. SOME PRODUCTS MAY NOT BE AVAILABLE IN ALL MARKETS. CONTACT YOUR LOCAL TEKNION REPRESENTATIVE FOR AVAILABILITY.

BROCHURE DESIGN: VANDERBYL DESIGN PRINTED IN CANADA SBO20022

